

PAGEPACKER SERVICES

Automation with imagination....



TOTAL BAG CONTROL SYSTEM

THE ACCURATE, FAST AND RELIABLE SACK CLOSING SYSTEM.

PAGEPACKER

Operation

Robust construction with stainless steel contact parts and food grade feeder belts gives smooth, fast and reliable sack conveying and closing prior to sealing by stitcher or heat sealer.

A sack is placed on a spout clamp, either manually, or by any Pacepacker Sackplacer, a pair of fingers then either stretch or reform the gussets of the bag.

A pair of motorised Grip Arms then move around the bag and as it drops from the clamp, they close on the bag, holding it in its formed state.

These arms then motor toward the sealer, releasing the bag into a twin belt feeder. Even very unstable products can be accommodated with ease as the bag top is held at all times prior to sealing, hence TBC – Total Bag Control.

TBC Options

Clamp Dust Reduction Pads
Retracting Under Posser
Sliding Guide Board for unstable products
Ticket Dispenser
Gusset Reforming System
Various Conveyor Lengths (0.5M increments)
Conveyor Mounted Rotary Sack Kicker

Control System

The stand-alone TBC control system utilises the latest PLC technology. When used with a Pacepacker Sackplacer, the TBC PLC system becomes a slave to the Sackplacers Master PLC. All motor drives are Inverter controlled for perfect speed matching.

Packing Speeds

Packing speeds depend on many factors such as weigher speed, filling time, conveyor speed etc. Typical speed for the TBC is 720 sacks per hour or 12 bags per minute. However speeds in excess of 900 bags per hour or 15 bags per minute are possible.

Weigher Requirements

Works with almost any fully automatic net or gross weigher or volumetric filler.

Sack Specification

Most commercial quality paper, plastic, WPP and laminated sacks are acceptable, providing they are in good condition. Hessian sacks can be used if they can be placed on the clamp.

Electrical Requirements

Standard: 415V, 50/60 Hertz 3 Phase + neutral, 10 Amp Supply. Alternatives can be accommodated.

Air Requirements

Cool, clean, dry air at 6 bar (90 PSI) at 27Litres (0.5 CuFt) per cycle. I.e. 6 cfm at 12 sacks per minute. Diameter 20mm (3/4") supply pipe minimum.

Shipping Specification

Depends on conveyor length and options fitted.



Typical Dimensions Shown, Equipment Manufactured To Suit Each Installation.

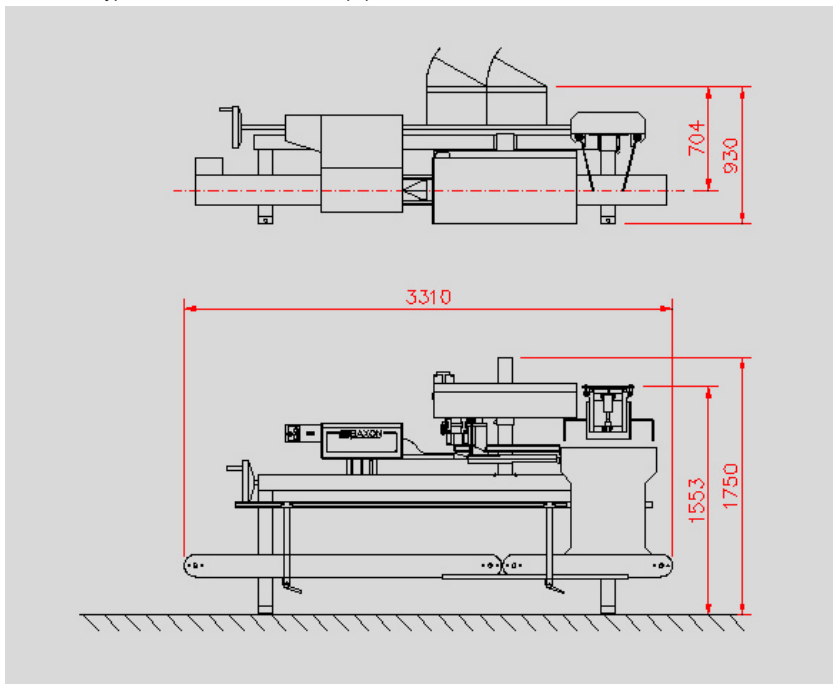

Pacepacker Services Limited

Unit 16 Bluegate Hall,
Great Bardfield,
Essex, CM7 4PZ.
England.

Tel: +44 (0) 1371 811544
Fax: +44 (0) 1371 811621

www.pacepackerservices.com